

# YKDK02A

Asansör Çift Kapılı Yarı Otomatik Kapı Kilidi

Interlock for Elevator Semi Automatic Double Swing Door

Form no: F32-1-R3

TR MONTAJ ve BAKIM KILAVUZU

ENG INSTALLATION AND MAINTENANCE MANUAL

AR كتيب التركيب

TSEK



[deltatek.com.tr](http://deltatek.com.tr)  
[deltatekelevator.com.tr](http://deltatekelevator.com.tr)



**DELTA TEK & LİFSOR**  
High Quality Elevator Components

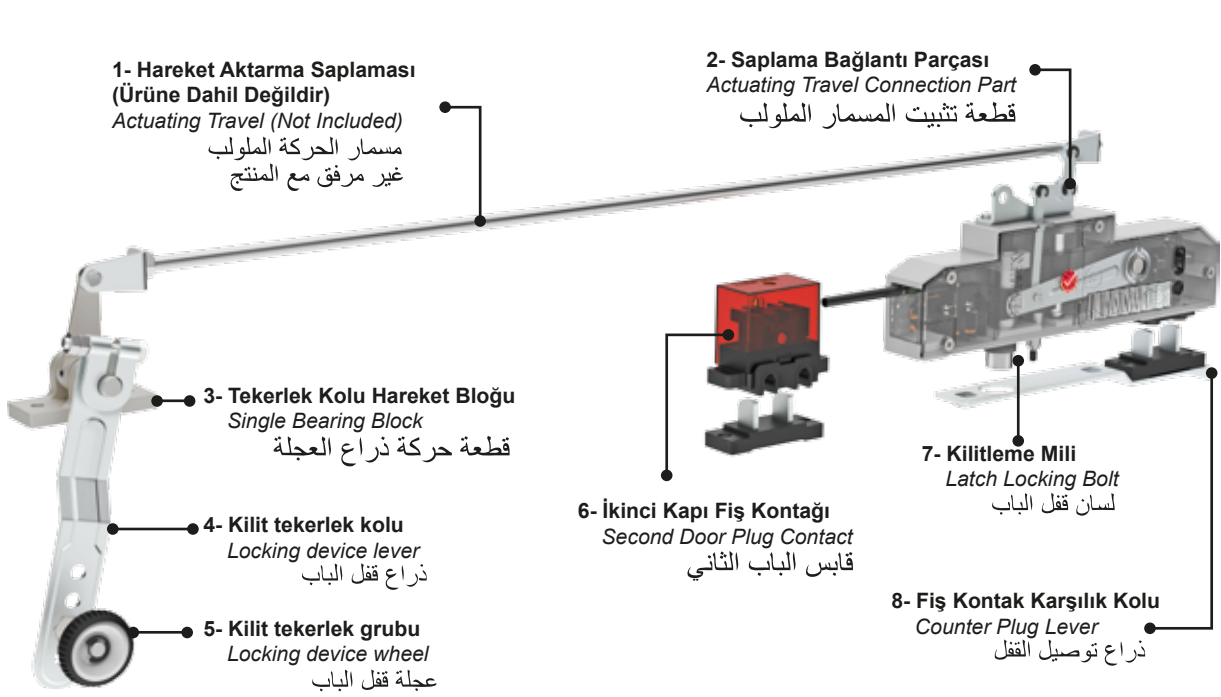

- Her hakkı saklıdır. Tüm fotoğraflar DELTATEK ASANSÖR SAN. TİC. LTD. ŞTİ. firmasına aittir. Bu dokümantasyonun tamamı veya bir kısmı kopyalanamaz, değiştirilemez veya başka bir dile tercüme edilemez. DELTATEK ASANSÖR SAN. TİC. LTD. ŞTİ., özellikle elektronik sistemleri kullanırken bu belgelerin işlenmesini, çoğaltılmasını veya saklanmasını kabul etmemektedir. All rights reserved. All photos are property of DELTATEK ASANSÖR SAN. TİC. LTD. ŞTİ. This documentation may not be copied, modified or translated into any other language in whole or in part. Especially when using electronic systems, DELTATEK ASANSÖR SAN. TİC. LTD. ŞTİ., have to agree to processing, duplication or storage of this documentator.

### BAKIM TALİMATI

Tüm hareketli parçalar gres yağı ile yağlandığı için normalde bakım yapılmasına gerek yoktur. Düzenli bakım dönemlerinde şunları öneriyoruz:

1. Toz ve kirliliğin gideriniz.
2. Sabitleme vidalarının sıkı bir şekilde sıkıldığını kontrol ediniz.
3. Tekerlek ve kolundaki sabitleme vidalarının sıkı olup olmadığını kontrol ediniz.
4. Gevşek olan elektrik kablolarını klemense tekrar sıkıca bağlayınız. Klemensin arızalı olduğunu tespit ederseniz kesinlikle değiştiriniz.
5. Kilitleme ve ikinci emniyet milinin yağı eskimişse gres yağı sürünüz.

### MAINTENANCE INSTRUCTIONS

Normally there is no maintenance necessary, because all moving bolts are provided with lubricants. In extreme operating conditions we suggest in regular inspection periods:

1. The removal of rough contamination.
2. To check that the fastening screws are tightly fastened.
3. To check that the screw at the roller and roller's lever is tightly fastened.
4. To retighten terminals for electrical cables. If you find that the terminal is defective, definitely replace it with a new one.
5. To lubricate again, if the lubricants have become ineffective.

### تعليمات الصيانة

القطع المتحركة بالقفل تم تشحيمها من المصنع لذلك لا داعي لإضافة الزيوت خلال فترة الصيانة الدورية نوصي بمايلي تأكد من إحكام براغي تثبيت القفل تحقق من البراغي والصامولات الموجودة على عجلة الذراع و ذراع القفل إذا كانت مشدودة أم لا إعادة توصيل الكابلات الساتبة إن وجدت وفي حال تلف أداة ربط الكابلات قم باستبدالها بأخرى جديدة أضف الشحم على لسان القفل وميل الأمان الثاني عند الحاجة لذلك

# KİLİTLEME DİLİNİN ÖLÇÜ TANIMI

## DEFINITION OF LATCH BOLD DIMENSION

مقاسات لسان قفل الباب

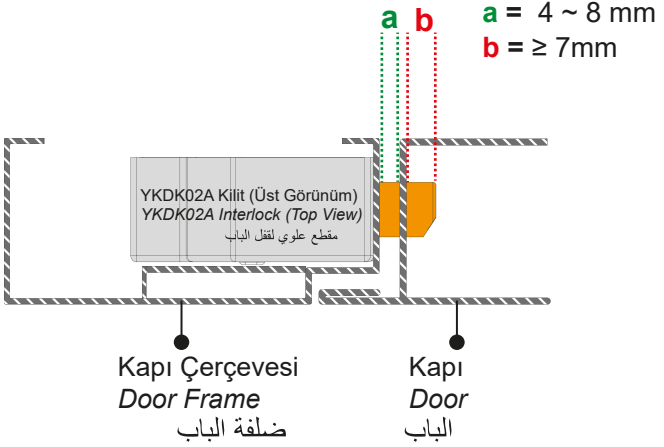

### 2.1. Eğer | If. | إذا (a < 4mm)

ⓉR İkinci emniyet pimi, kapı ve kapı çerçevesinin arasındaki mesafe dar olduğu durumlarda devreye girmeyebilir. Bu gibi durumlarda ambalaj içerisinde bulunan uygun yükseltici plastik tamponu (1 veya 2 mm) aşağıdaki görseldeki sabitleyiniz. (Plastik tamponlar aynı zamanda ses izolasyonu sağlar.)

ⓄNG Second safety bolt may not activate because of the distance between the door and the door frame is narrow. In such cases, use the appropriate support plastic pad which included in the packaging as shown in the image below. (Plastic bumpers also provide sound insulation.)

ⓂR إذا كانت المسافة بين الباب أو إطار الباب ضيقة قد لا يعمل ميل الأمان الثاني في حال واجهتم هذه المشكلة استخدم القطع لبلاستيكية الموجودة في علبة القفل لضبط بعد القفل كما هو مبين في الرسم أدناه (كما تعمل القطع البلاستيكية على عزل الصوت)

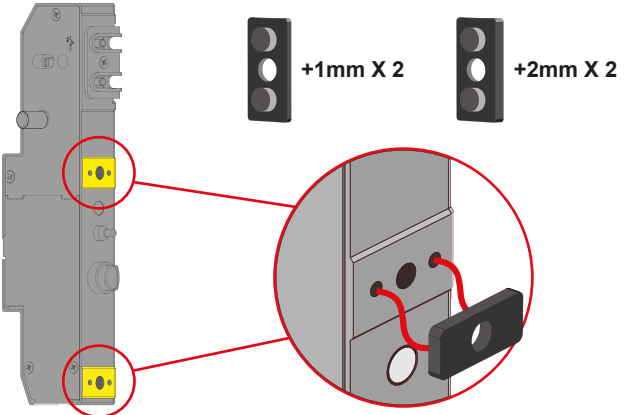

# KUTU İÇERİĞİ | BOX CONTENTS | محتوى العبة

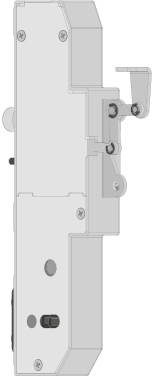

- (TR) Kapı Kilidi  
(ENG) Door Interlock  
(AR) قفل الباب

X1

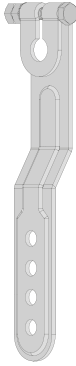

- (TR) Tekerlek Kolu  
(ENG) Roller Lever  
(AR) ذراع قفل الباب

X1

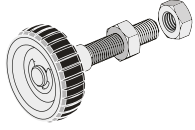

- (TR) Tekerlek ve Civatası  
(ENG) Roller and Bolt  
(AR) عجلة ذراع القفل

X1

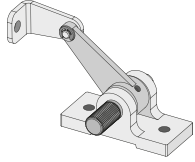

- (TR) Tekerlek Kolu Hareket Bloğu  
(ENG) Single Bearing Block  
(AR) قطعة حركة ذراع العجلة

X1

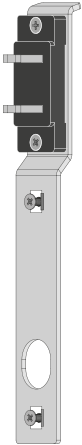

- (TR) Kapı Kontak Kolu  
(ENG) Door Contact Lever  
(AR) ذراع توصيل القفل

X1

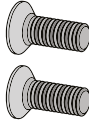

M5x15HB

- (TR) Bağlantı Vidası  
(ENG) Door Contact Bolt  
(AR) براغي التثبيت

X2

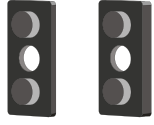

1 mm 2 mm

- (TR) Yükseltici Tampon  
(ENG) Leveling Buffer  
(AR) بلاستيك لضبط بعد القفل

X2

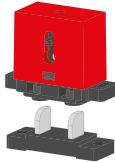

- (TR) İkinci Kapı Fiş Kontak ve Devre Tamamlayıcı Karşılığı  
(ENG) Second Door Plug Contact with Circuit Complement Device  
(AR) قابس الباب الثاني

X1

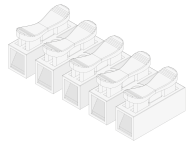

- (TR) Klemens Terminal  
(ENG) Terminal  
(AR) أداة ربط الكابلات

X1

**AB UYGUNLUK BEYANI****EU DECLARATION OF CONFORMITY FOR SAFETY COMPONENTS FOR LIFTS**

<b>İmalatçı / Manufacturer:</b>	DELTATEK ASANSÖR LTD. ŞTİ. SAN. TİC.
<b>Firma / Company:</b>	DELTATEK ASANSÖR LTD. ŞTİ. SAN. TİC.
<b>Adres / Adress:</b>	İmes Sanayi Sitesi C/308 Sokak No.: 6 Yukarı Dudullu Ümraniye İstanbul -TÜR.
<b>Fabrika / Factory:</b>	İmes Sanayi Sitesi C/308 Sokak No.: 6 Yukarı Dudullu Ümraniye İstanbul -TÜR.
<b>Yetkili Kişi / Authorised Representative:</b>	Ahmet GÜL ERBOZ
<b>Tip / Type:</b>	YKDK02A-SAĞ, YKDK02A-SOL
<b>Seri No / Serial Number:</b>	ETİKET ÜZERİNDE BELİRTİLMİŞTİR. (2024 YILINDA ÜRETİLEN HER ÜRÜN İÇİN) GIVEN ON PRODUCT LABEL ( ALL PRODUCTS WHICH MANUFACTURED IN 2024)
<b>Üretim Tar. / Prod. Date:</b>	2024

**Uygunluk Değerlendirme Prosedürü / Conformity Assessment Procedures**

<b>Rasgele Kontrol ile Tip Uygunluğu (Modül C 2) Sertifika Numarası / Conformity to Type with Random Checking (mod. C 2) Certificate number:</b>	LS/C-113/24
<b>AB Tip Test Sertifika Numarası (Modül B) EU-Type Examination (module B) Certificate Number :</b>	LF/KSA/A-C-0179/17

<b>C2 Modül / C2 Module:</b>	GCN TURK	 2729
<b>B Modül / B Module:</b>	MIRTEC	 0437

**Üretimi yapılan güvenlik bileşeninin aşağıdaki yönetmelik ve standartlara uygunluğunu beyan ederiz. / We hereby confirm that the safety component complies with the following directives and harmonized standards:**

<b>Asansör Yönetmeliği / Elevator Norms:</b>	2014/33/EU	Lifts Directive
	EN 81-20:2020	Safety rules for the construction and installation of lifts – Lifts for the transport of persons and goods – Part 20: Passenger and goods passenger lift
	EN 81-50:2020	Safety rules for the construction and installation of lifts – Examinations and tests – Part 50: Desing rules, calculations, examinations and tests of lift components

**Firma Kaşe, İmza / Company Stamp, Signature****DELTATEK & LİFSOR**  
High Quality Elevator Components

# YKDK02A KAPI KILIDI ÖLÇÜLERİ | YKDK02A DOOR INTERLOCK DIMENSIONS | مقاسات قفل الباب

Ölçüler mm cinsindedir. / Dimensions are in mm. / وحدة القياس المستخدمة هي ملم

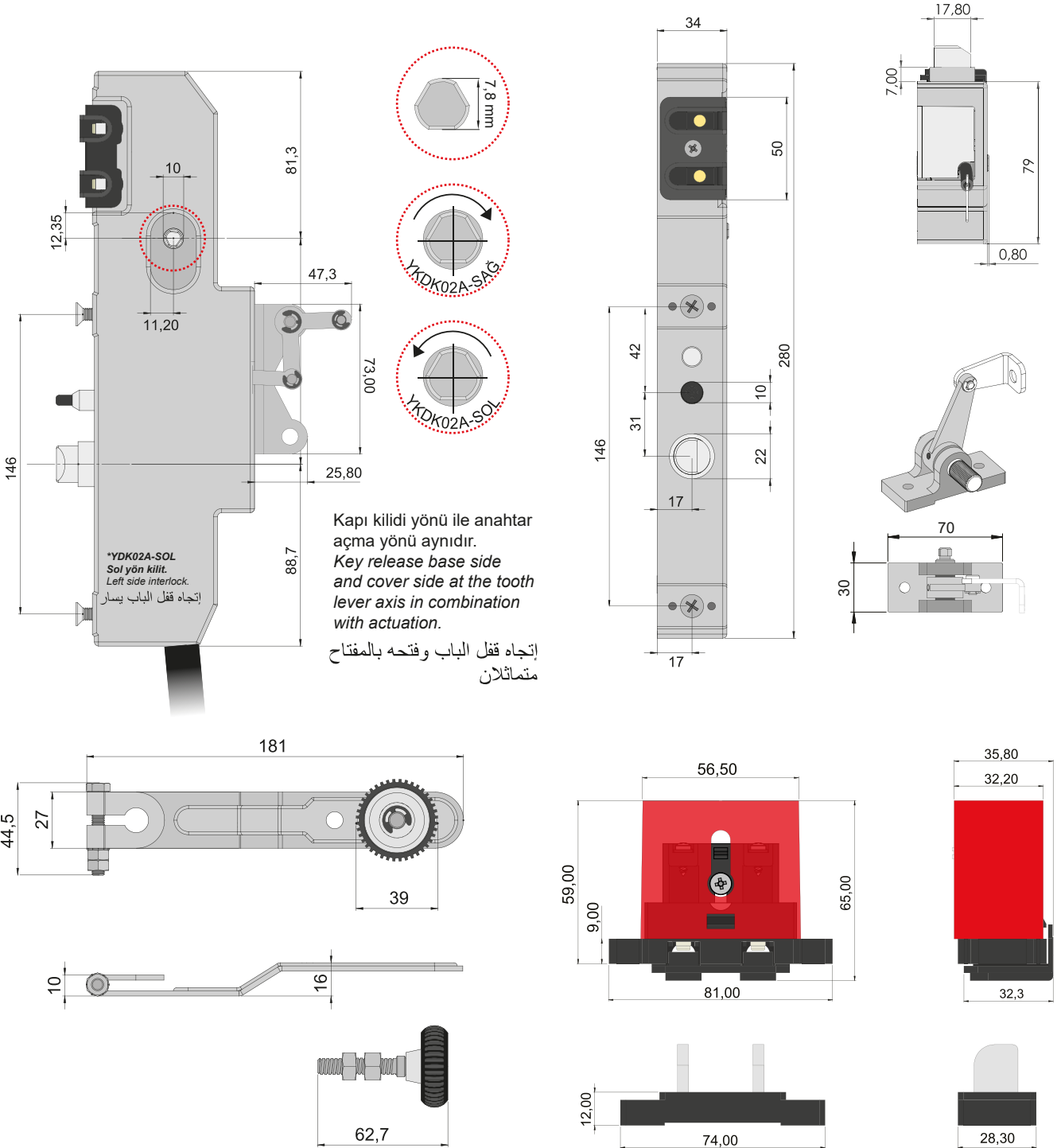

1

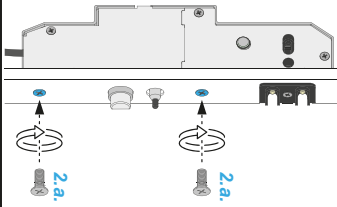

(TR) Kapı kilidini, kapı çerçevesindeki yerine vidalar ile sabitleyiniz. (2.a.)

(ENG) Fix the interlock in place on the door frame with screws. (2.a.)

(AR) قم بتركيب القفل في مكانه على إطار الباب وتثبيتته بالبراغي كما هو مبين في الرسم (2.a.)

2

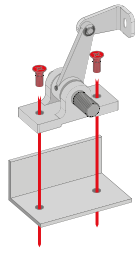

(TR) Tekerlek kolu hareket bloğunu kapı kasası üzerindeki yerine vida ile sabitleyiniz.

(ENG) Assemble the single bearing block in place on the top door frame with screw.

(AR) قم بتثبيت قطعة حركة ذراع العجلة في مكانها على إطار الباب باستخدام البراغي كما هو مبين في الرسم

3

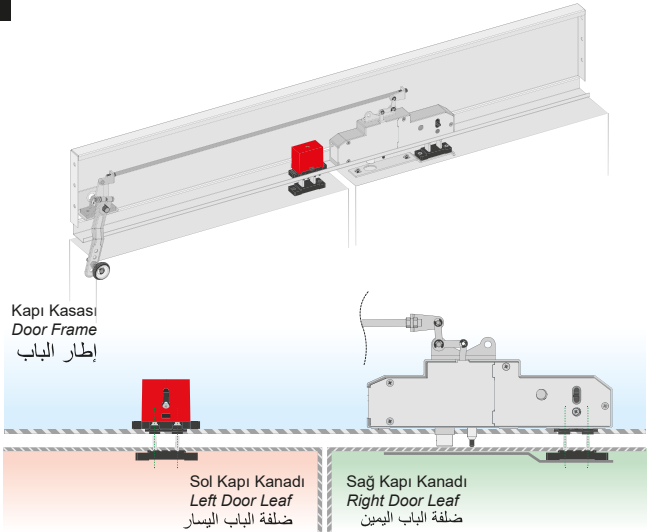

Kapı Kasası  
Door Frame  
إطار الباب

Sol Kapı Kanadı  
Left Door Leaf  
ضلفة الباب اليسار

Sağ Kapı Kanadı  
Right Door Leaf  
ضلفة الباب اليمين

(TR) Kilit fiş kontağı karşılığı olan kapı kontak kolunu kapı kanadındaki yerine sabitleyiniz. Daha sonra ikinci kapı kanadı fiş kontağını kapı kasasına sabitledikten sonra devre tamamlayıcı karşılığını da kapı kanadındaki yerine monte edip sabitleyiniz.

(ENG) Fix the counter plug lever, which corresponds to the interlock plug contact, in place on the door leaf. Then, after fixing the second door leaf's plug contact to the door frame, mount and fix the circuit complementary counterpart in its place on the door leaf.

(AR) قم بتثبيت ذراع التوصيل المقابلة لقابس قفل الباب في مكانها على ضلفة الباب بعد ذلك قم بتثبيت قابس الباب الثاني على إطار الباب وتركيب الجهة المقابلة له (القطعة المتممة للدائرة الكهربائية) في مكانها على ضلفة الباب كما هو مبين في الرسم

**(TR)** Tekerlek kolu hareket bloğu ile saplama bağlantı parçası arasına hareketi aktarmak için tij monte edip somunlarını sıkınız. Aşağıdaki görseldeki gibi pompa yönüne göre saplama bağlantı parçasının yönünü değiştirebilirsiniz.

**(ENG)** Mount the rod and tighten the nuts to transfer the movement between the single bearing block and actuating travel connection part. You can change the direction of the actuating travel connection part according to the retiring cam direction as shown in the image below.

**(AR)** قم بتركيب المسمار الملولب بين قطعة حركة ذراع العجلة والمكان المخصص لها على القفل و إحكام شد الصامولات كما يمكن تغيير إتجاه قطعة توصيل المسمار على القفل حسب إتجاه الكامه كما هو مبين في الرسم أدناه

**Örnek: YKDK02-A SOL yönlü kilidin tekerlek kolu hareket bloğunu sağ yöne monte etmek isterseniz aşağıdaki görseldeki gibi saplama bağlantı parçası üzerindeki kollarin yönünü pimleri sökerek değiştirebilirsiniz. Not: Tij bağlantı sacı pozisyonunu aşağıdaki uyarıyı dikkate alarak ayarlayınız.**

If you want to mount the single bearing block in the right direction on the door frame, you can change the direction of the actuating travel connection part by removing the pins and retaining ring as shown in the image below.  
Note: Adjust the stud connection sheet position by taking the following **warning** into account.

مثال: إذا كان إتجاه قفل الباب يسار وأردتم تركيب قطعة حركة ذراع العجلة على اليمين قم بفك قطعة تثبيت المسمار والذراع الحامل لها عن طريق فك الميل الموجود على كليهما وتثبيتهما كما هو مبين في الرسم أدناه  
ملاحظة: قم بضبط إستقامة و زاوية أماكن تركيب المسمار الملولب مع مراعاة التحذير أدناه

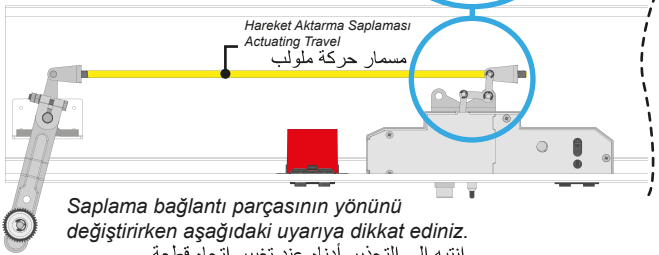
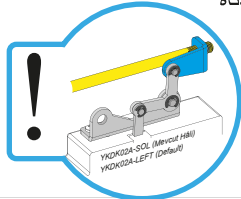

Saplama bağlantı parçasının yönünü değiştirirken aşağıdaki uyarıya dikkat ediniz.

إنتبه الى التحذير أدناه عند تغيير إتجاه قطعة تثبيت مسمار الحركة على القفل

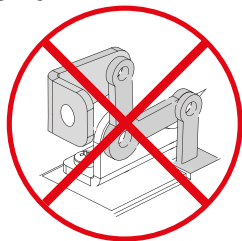
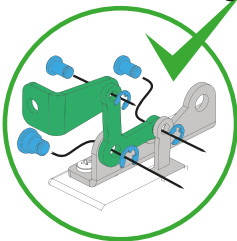



**(TR)** Tekerlek kolunu mile sabitlemeden önce, kapı açma magnetinin kilit açma kolu çekili pozisyondayken tekerleğin pompa kilit açma koluna teğet degecek açıda ayarlayıp (5.a.) somunlarını sıkınız. (5.b.)

**(NG)** Before tightening the roller lever to the axle, make sure that the wheel is tangent the lever of retiring cam while retiring cam locking position. (5.a.) After that tighten the bolts. (5.b.)

**(AR)** قبل تثبيت ذراع العجلة على عامود القفل إضبطة بزاوية تلامس ذراع الكامه لإخاسة بالعجلة في وضع السحب ثم قم بإحكام شد الصامولات

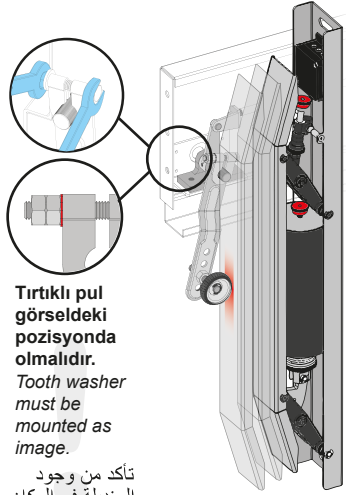

**Tırtıklı pul görseldeki pozisyonunda olmalıdır.**  
Tooth washer must be mounted as image.

تأكد من وجود الرنديلة في المكان المخصص لها كما هو مبين في الرسم

## GARANTİ ŞARTLARI | WARRANTY CONDITIONS | شروط الضمان

- Kullanım kılavuzunda belirtilen esaslara, uyarılara ve standartlara uyulmak koşulu ile DELTATEK ASANSÖR markalı DK02A imalat hatalarına karşı 2 (iki) yıl DELTATEK ASANSÖR garantisindedir.
- Garanti süresi başlama tarihi ürün üzerindeki etiketin tarihidir.
- Comply with the principles, warnings and standards specified in the user manual DELTATEK ASANSÖR branded DK02A manufacturing, provided that It is under DELTATEK ELEVATOR warranty for 2 (two) years against faults.
- The warranty period starting date is the date on the label on the product.

نخضع DELTATEK ASANSÖR لضمان لمدة عامين ضد عيوب التصنيع على أن يتم الإلتزام بالمبادئ والتحذيرات والمعايير المحددة في دليل المستخدم يتم تحديد تاريخ بدء فترة الضمان بختم على شهادة الضمان

### İMALATÇI FİRMANIN BİLGİLERİ;

**ÜN VAN:** DELTATEK ASANSÖR SAN. VE TİC. LTD. ŞTİ  
**MERKEZ ADRES:** İMES SANAYİ SİTESİ C BLOK 308 SOK.  
**NO:** 6 YUKARI DUDULLU - ÜMRANİYE / İST. TÜRKİYE  
**TELEFON:** + 90 216 364 30 35

### ÜRÜN BİLGİLERİ;

**CİNSİ:** ASANSÖR YEDEK PARÇA  
**MARKASI:** DELTATEK ASANSÖR  
**MODELİ;** DK02A-SAĞ / DK02A-SOL



# ELEKTRİK BAĞLANTISI | ELECTRICAL CONNECTION |

مخطط توصيل الكابلات الكهربائية

 Sarı / Yeşil Kablo = Topraklama  
Yellow / Green Cable = Ground  
كابل التأريض

 Kahverengi Kablo = Kilit Fiş Kontak  
Brown Cable = Interlock Plug Contact  
كابل قابس القفل

 Siyah Kablo = Kapı Fiş Kontak  
Black Cable = Door Plug Contact  
كابل قابس الباب

